

Consultation Questionnaire Exemption 6(b) of RoHS Annex III

Table 1: Currently valid wordings of the exemption 6(b) series

| No. | Exemption | Scope and dates of applicability |
|--------------|---|--|
| III-6(b) | Lead as an alloying element in aluminium containing up to 0,4 % lead by weight | Applies to categories 8, 9 and 11, and expires on <ul style="list-style-type: none"> - 21 July 2021 for cat. 8 other than in-vitro diagnostic medical devices, and cat. 9 other than industrial monitoring and control instruments - 21 July 2023 for category 8 in-vitro diagnostic medical devices - 21 July 2024 for category 9 industrial monitoring and control instruments, and for category 11 |
| III-6(b)(I) | Lead as an alloying element in aluminium containing up to 0,4 % lead by weight, provided it stems from lead-bearing aluminium scrap recycling | Expires on 21 July 2021 for categories 1-7 and 10 |
| III-6(b)(II) | Lead as an alloying element in aluminium for machining purposes with a lead content up to 0,4 % by weight | Expires on 18 May 2021 for categories 1-7 and 10 |

Acronyms and Definitions

Cat. Category, referring to the categories of EEE specified in Annex II of the current RoHS Directive

COM European Commission

EEE Electrical and electronic equipment

IMCI Industrial monitoring and control instruments

Lead-free Not containing lead in the applications in the scope of the exemption to be reviewed

Pb Lead

1. Background and objectives of this review

Bio Innovation Service, UNITAR-SCYCLE and Fraunhofer IZM have been appointed¹ by the European Commission for the evaluation of applications for new exemptions and the renewal of exemptions currently listed in Annexes III and IV of the RoHS Directive 2011/65/EU.

TMC requested the renewal of exemption 6(b) with its current wording for the maximum validity of seven years for cat. 9 industrial monitoring and control instruments (IMCI). EUROMOT request the renewal of exemptions 6(b)(I) and 6(b)(II) for the maximum validity period of five years respectively. The National Association of Manufacturers (NAM) support EUROMOTS request.

The applicants were requested to respond to clarification questionnaires prior to this stakeholder consultation to complete missing information. These questionnaires along with the exemption applications and – if submitted - supporting evidence from other stakeholders are accessible on the consultation web page.

The stakeholder consultation is part of the review process for the exemption request at hand. It addresses third parties – not the applicants – to provide and to evaluate information and evidence according to the criteria listed in Art. 5(1)(a) of Directive 2011/65/EU.²

Exemptions 6(b), 6(b)(I) and 6(b)(II) were reviewed by Baron et al. (2022)³. They recommended maintaining the current exemption 6(b) with the same wording and expiry dates as listed in Table 1. They further on recommended renewing exemptions 6(b)(I) as exemption 6(b)(III), and exemption 6(b)(II) as exemption 6(b)(IV) like listed in the below table.

Table 2: Recommended renewal of the current exemptions 6(b)(I) and 6(b)(II) in the last review in 2021/2022

| | Exemption formulation | Duration |
|----------|---|---|
| 6(b)-I | <i>Lead as an alloying element in aluminium containing up to 0,4% lead by weight provided it stems from lead-bearing aluminium scrap recycling</i> | Expires 12 months after the decision for all categories |
| 6(b)-III | <i>Lead as an alloying element in aluminium casting alloys containing up to 0,3% lead by weight provided it stems from lead-bearing aluminium scrap recycling</i> | Expires on 21 July 2026 for all categories |

¹ It is implemented through the specific contract 070201/2020/832829/ENV.B.3 under the Framework contract ENV.B.3/FRA/2019/0017

² Directive 2011/65/EU (RoHS) available at <http://eur-lex.europa.eu/LexUriServ/LexUriServ.do?uri=CELEX:32011L0065:EN:NOT>

³ C.f. Öko-Institut, https://rohs.exemptions.oeko.info/fileadmin/user_upload/RoHS_Pack_22/RoHS_Pack-22_final_report_amended_February_2022.pdf

| | Exemption formulation | Duration |
|---------|--|---|
| 6(b)-II | Lead as an alloying element in aluminium for machining purposes with a lead content up to 0,4 % by weight. | Expires 18 months after the decision for all categories |
| 6(b)-IV | Lead as an alloying element in aluminium for machining purposes with a lead content up to 0,4 % by weight in gas valves applied in category 1 EEE (large household appliances) | Expires on 31 December 2024 |

Source: Baron et al. (2022)

The European Commission (COM) have not yet officially published their decision as to the adoption of the above recommendation. The COM wishes the consultants to assess in this current review round whether there are any substantial reasons in line with Art. 5(1)(a) against the adoption of the above recommendation for EEE of categories 8, 9 and 11. This implies that the consultants will assess whether the validities of exemptions whose renewal is requested for cat. 8, 9 or 11 may exceed the validities recommended in the previous review (Table 2). **Error! Reference source not found.** reflects the potential scope and w ordings if the exemptions are renewed for cat. 9 IMCI and for cat. 11.

Table 3: Renewal of current exemption 6(b)(I) and 6(b)(II) for cat. 9 and 11 as exemptions 6(b)(III) and 6(b)(IV) based on the recommendation of Baron et al. (2022)

| No. | Recommended Exemption | Recommended scope and dates of applicability |
|---------------|---|--|
| III-6(b) | Lead as an alloying element in aluminium containing up to 0,4 % lead by weight | Applies to categories 8, 9 and 11. Expires on <ul style="list-style-type: none"> - 21 July 2021 for cat. 8 other than in-vitro diagnostic medical devices, and cat. 9 other than industrial monitoring and control instruments - 21 July 2023 for category 8 in-vitro diagnostic medical devices - 21 July 2024 for category 9 industrial monitoring and control instruments - [21 July 2024 + 18 months, or date of official publication of the COM decision + 18 months if the publication date is later than 21 July 2024] for category 11 |
| III-6(b)(III) | Lead as an alloying element in aluminium casting alloys containing up to 0,3 % lead by weight provided it stems from lead-bearing aluminium scrap recycling | Applies to <ul style="list-style-type: none"> - categories 1-7 and 10 - category 9 monitoring and control instruments other than industrial monitoring and control instruments from [date of expiry of III-6(b) + 1 day] on - category 9 industrial monitoring and control instruments from [date of expiry of III-6(b) + 1 day] on |

| | | |
|--------------|---|---|
| | | <ul style="list-style-type: none"> - category 11 from [date of expiry of 6(b) + 1 day] on <p>Expires on</p> <ul style="list-style-type: none"> - 21 July 2026 for categories 1-7 and 10, and for category 9 monitoring and control instruments other than industrial monitoring and control instruments. - 21 July [2026 + A] for cat. 9 industrial monitoring and control instruments - 21 July [2026 + C] for cat. 11 |
| III-6(b)(IV) | Lead as an alloying element in aluminium for machining purposes with a lead content up to 0,4 % by weight | <p>Applies to</p> <ul style="list-style-type: none"> - gas valves in category 1 from 31 December 2024. - category 9 monitoring and control instruments other than industrial monitoring and control instruments from [date of expiry of III-6(b) + 1 day] on - category 9 industrial monitoring and control instruments from [date of expiry of 6(b) for cat. 9 + 1 day] on. - and cat. 11 from [date of expiry of 6(b) for cat. 11 + 1 day] on <p>Expires on</p> <ul style="list-style-type: none"> - 31 December 2024 for category 1 - - 21 July [2024 + B] for cat. 9 industrial monitoring and control instruments - 31 July [2024 + D] for cat. 11 |

A and D can be 5 years maximum.

B can be 7 years maximum.

C can be 3 years maximum

*Note: Exemption 6(b)(IV) could be renewed as 6(b)(II) as well. The wording of exemption 6(b)(IV) in the above Table 3 is identical to the wording of the current exemption 6(b)(II) after the shift of the “gas valves applied in category 1” from the exemption wording by Baron et al. (2022) in **Table 2** to the exemption scope. The consultants will follow up on this in the further review of the exemption requests.*

To contribute to this stakeholder consultation, please answer the below questions until 11 December 2023.

Please also see the applicants’ request form and clarification questionnaire response and – if submitted – further information on the consultation web page⁴.

⁴ Consultation web page: <https://rohs.biois.eu/requests2.html>

2. Questions

Baron et al. (2022) state that the 0.3 % for lead in exemption 6(b)(III) is adapted to the current market situation and closes the door to alloys with higher lead contents that remain available on the market but do not serve a functional purpose. EN standardisation processes for aluminium alloys and international standards for aluminium alloys already have lead thresholds below 0.4 % Although no exact data for lead content in the international supply chain is known, the consultant believes that the limit value of 0.3% can be complied with internationally, because a lead content of 0.35 % has already been specified in the international standards since 2007. Thus, the availability of suitable aluminium alloys is assumed to be given. EU Aluminium supported reducing the maximum lead limit to 0.3 %

- 1) In their answers to the clarification questionnaire EUROMOT do not agree that exemption 6(b)(III) would cover their applications in EEE of cat. 11. They claim that up to 0.4 % of lead concentration are still required rather than the 0.3 % of lead permitted in exemption 6(b)(III). EUROMOT members still use aluminium parts with up to 0.4 % of lead in special types of engines some of which are sold in only small numbers. Stocks of parts for these special types of engines may last for up to seven years before they are consumed, and new batches of parts are obtained. Some of the parts currently in stock contain between 0.3 % and 0.4 % lead. With exemption 6(b)(III) becoming applicable instead of the current 6(b)(I), these parts will become waste which has a considerable environmental impact.
 - a. In the light of the above, do you support EUROMOT's claim that exemption 6(b)(III) does not cover their members' needs? Can't it be reasonably assumed that the members started compliance efforts in the past already so that they are ready to comply with exemption 6(b)(III) by the time it expires in 2026?
 - b. Do you know of any applications of relevance for devices produced by EUROMOT members where exemption 6(b)(III) can already - or at latest can be – complied with by July 2026?
 - c. Vice versa, are you aware of applications where this is scientifically and technically still impracticable?
- 2) EUROMOT agree that exemption 6(b)(IV) covers their applications of lead instead of exemption 6(b)(II). They requested that exemption 6(b)(IV) remains valid for 5 years beyond 2024 (i.e. D = 5 years in Table 3). They state that this time is necessary to undertake essential testing as outlined in section 7 of their exemption renewal request.
- 3) In their answers to the clarification questionnaire, TMC insist that exemption 6(b) shall be renewed for cat. 9 IMCI as requested in their exemption renewal application, and that exemptions 6(b)(III) and 6(b)(IV) are not applicable. They justify their statement with additional administrative burdens arising from changes in exemption architectures and numberings and provide technical arguments for the renewal of exemption 6(b) without specifically addressing technical obstacles that might arise if

exemption 6(b)(III) with its reduced lead content (0.3 % instead of 0.4 %) became applicable to cat. 9 IMCI. TMC indicate in their exemption renewal request that the content of lead in aluminium applied in cat. 9 IMCI is lower than 0.04 %.

- a. In the light of the statements of Baron et al. (2022), do you support TMC's claim that exemption 6(b)(III) does not cover their members' needs? Can't it be reasonably assumed that the members started compliance efforts in the past already so that they are ready to comply with exemption 6(b)(III) by the time it expires in 2026?
 - b. Do you know of any applications of relevance for devices produced by TMC members (cat. 9 IMCI) where exemption 6(b)(III) can already - or at latest can - be complied with by July 2026?
 - c. Vice versa, are you aware of applications where this is scientifically and technically still impracticable?
- 4) TMC provided a socioeconomic analysis related to the above exemption request. The document is available online in the consultation folder for this exemption. Do you agree with the underlying method, data and conclusions?
- 5) Is there any additional information which you would like to provide?

This comment is submitted in the name of Afecor, the European control manufacturer association.

Our members are all major companies which provide safety controls for residential and commercial applications and also for industrial processes (melting, burning or drying for metal, ceramics and food industries) using gaseous and liquid fuels and for the distribution of fuels, including renewable and low carbon gases, like Hydrogen, Biomethane, efuels, etc, which are essential for our society and the energy transition and decarbonization of European energy use in accordance with the Green Deal and the following implementation strategy (Fit for 55, REPowerEU, etc.).

Further information on our association and the products (controls) we manufacture can be found on our website <https://www.afecor.org>

Afecor is composed of 16 members, they cover more than 80% of their EU market.

Afecor **agree and support** the proposal of EUROMOT in the consultation document, as shown below:

2) EUROMOT agree that exemption 6(b)(IV) covers their applications of lead instead of exemption 6(b)(II). They requested that exemption 6(b)(IV) remains valid for 5 years beyond 2024 (i.e. D = 5 years in table 3). They state that this time is necessary to undertake essential testing as outlined in section 7 of their exemption renewal request.

Furthermore, Afecor support the EUROMOT request of exemption 6(b)(IV) - Lead as alloying element in aluminum remains valid for 5 years beyond 2024 (i.e. D = 5 years in table 3) also for the following categories:

Category 1: Large household appliances

Category 2: Small household appliances

Detailed Explanation of our position

The machinability and component's life tests on the gas valves made with new aluminum alloys without lead have not yet been completed for the contingent market supply situation in which we have found working in recent years (Covid pandemic, Ukraine war, energy price) which caused a disruption of worldwide supply chain.

The new aluminum alloys without lead cannot guarantee the complete absence of micro-burrs on the machined parts creating possible "safety issues due to gas leakage". Currently the gas valves technology guarantees the gas seal through metallic "cone-body" coupling so the presence of also few micro-burrs can create scratches on cone/body during their activation/rotation. See drawing below of a typical solution from EN1106.

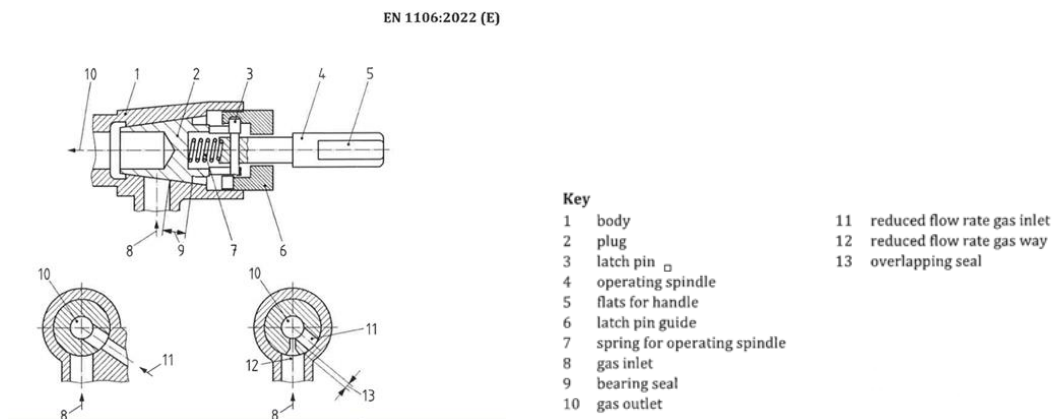

Afecor primarily supports an exemption of dangerous substances by way of a time derogation for the applications relevant for its members to perform the research, necessary to find and implement alternatives and do re-certifications that meet the high level of requirements of the laws, regulations and safety standards applicable to our industry.

We have already started the process of evaluating the replacement of current aluminium alloys and this process requires re-design, testing, and process approvals.

In general, there are challenges for the replacement / substitution process:

- Identifying and developing alternatives that can meet the safety and performance requirements
- Time for material qualifications / approvals
- Full process re-design
- Endurance testing
- Certification of the control
- Certification of the final appliance

Therefore more time is needed in our industry to complete the new alloys machinability analysis and related approval activities so Afecor support the EUROMOT request asking to extend the exemption 6(b)(IV) to 5 years beyond 2024 as described in point 2) of the consultation document also for categories 1 and 2.

Please note that answers to these questions can be published on the stakeholder consultation website and in the review report. If your answers contain confidential information, please provide a version that can be made public along with a confidential version, in which proprietary information is clearly marked.

Please do not forget to provide your contact details (Name, Organisation, e-mail and phone number) so that the project team can contact you in case there are questions concerning your contribution.

It would be helpful for the review process if you could kindly provide the information in formats that allow copying text, figures and tables to be included in the review report.